

- 1) Identification code: **M3 EMERGENCY EXIT DEVICE**
- 2) Identification number: 4203201.001 KIT M3 leaf thickness 60mm  
 4203201.002 KIT M3 leaf thickness 50mm  
 4203201.003 KIT M3 leaf thickness 40mm
- 3) Intended product use: Emergency exit device for escape routes suitable for one-leaved doors or for the active leaf of two-leaved doors with dimensions up to 1350x2880mm/leaf, mass up to 300kg/leaf, mounted on hinges or pivots, with fire resistance up to EI<sub>2</sub>120 - REI120 and smoke proof. Projection of the handle 67mm.
- 4) Manufacturer: NINZ S.p.A. - corso Trento 2/A  
 I-38061 ALA (TN) www.ninz.it  
 tel. +39 0464 678300 - fax +39 0464 679025
- 5) Auth. representative: -
- 6) Assessment perf. sys.: system 1
- 7) Harmonized standard: EN 179:2008
- 8) Notified body: ICIM S.p.A. N.B. nr. 0425 have issued the certificate of conformity for the factory production control nr. 2147-CPD-2010.

- 9) Declared performances:
- | Essential characteristics               | Performance-grade          | Paragraph |
|---|----------------------------|-----------|
| Category of use                         | 3 - high frequency         | 7.1       |
| Durability                              | 7 - 200.000 cycles         | 7.2       |
| Door mass                               | 7 - over 200kg             | 7.3       |
| Suitability for use on fire/smoke doors | B - suitable               | 7.4       |
| Safety toward people                    | 1 - for emergency exits    | 7.5       |
| Corrosion resistance                    | 4 - 240 h (very high res.) | 7.6       |
| Security toward goods                   | 4 - 3000N                  | 7.7       |
| Projection of operating element         | 2 - up to 100mm            | 7.8       |
| Type of operation                       | A - lever handle           | 7.9       |
| Field of door application               | A - 1 or 2 leaved door     | 7.10      |
| Dangerous substances                    | conform                    | ZA        |
- 10) Emergency devices listed in point 1 and 2 are conform to the performances declared in point 9. This declaration of performance is issued under the exclusive responsibility of the manufacturer listed in point 4.

Signed in the name and on behalf of the manufacturer:

Ninz Karl  
 legal representative of the NINZ S.p.A.

## INSTALLATION, USE AND MAINTENANCE HANDBOOK

**A191-GB**  
5001288/2 - 02/14

### SYMBOLS EMPLOYED

- CAUTION**  
 Indicates a danger that threatens people and/or material goods. Failure to observe the warnings indicated by this symbol may have serious consequences, such as personal injury and property damage.
- ATTENTION**  
 Indicates a danger that threatens material goods. Failure to observe the warnings indicated by this symbol may result in damage to material goods.
- NOTICE**  
 Warnings related to important technical aspects.

### PRODUCT DESCRIPTION

Emergency device for one-leaved doors or for the active leaf of two-leaved doors located at emergency exits and activated by lever handle. Composed of installation plates and threaded square spindle in galvanized steel, internal and external lever handle with steel core and cover plate in black plastic, panic safe lock and nickel-plated brass cylinder with three keys.

### OPERATION MODE

From the pull side the door cannot be opened if the panic safe lock is closed by key whereas opening is possible from the push side at any time by using the lever handle.

### WARNINGS

The M3 handle for emergency exit is intended for the installation on doors to used by people that are accustomed to use the controls of the panic devices for escape routes. Therefore their use is suitable when a panic situation is very unlikely.

The safety features of this product are of fundamental importance to ensure its conformity with EN 179. It is strictly forbidden to introduce any type of modifications apart from those described in these installation instructions.

### RECOMMENDATIONS

To ensure high level of human safety and appropriate safety levels for material goods, the handle for emergency exit must be installed on doors and doorframes that are in good conditions. The installation of the door itself, therefore, should be checked to ensure that it was installed properly and that nothing obstructs its normal movement.

If rebate sealing are mounted on the door, make sure they do not inhibit proper functioning of the panic exit device.

In case of two-leaved door where both leaves are equipped with emergency devices or in combination with a panic bar, it is mandatory to check that each leaf opens when its respective device is activated and that leaves open freely when the devices are activated simultaneously.

The fastening instructions in the present document should be followed scrupulously during installation. Once installation is complete, the installer should give this document to the owner of the activity.

For securing the door in the closed position, do not employ any other latching devices than those specified in the present document. This does not preclude the installation of automatic closing devices.

The M3 emergency device is also designed for installation on hollow metal doors with an internal cell structure.

If a door closer is needed to return the door to the closed position, care should be taken not to make the opening step more difficult for children, the elderly and the disabled.

A pictogram (arrow) should be positioned immediately above the handle activation lever on the internal side of the door.

All of the included components described herein must be positioned and mounted in conformity with the present document.

Any cylinder supplied by the customer must comply with DIN standard 18254.

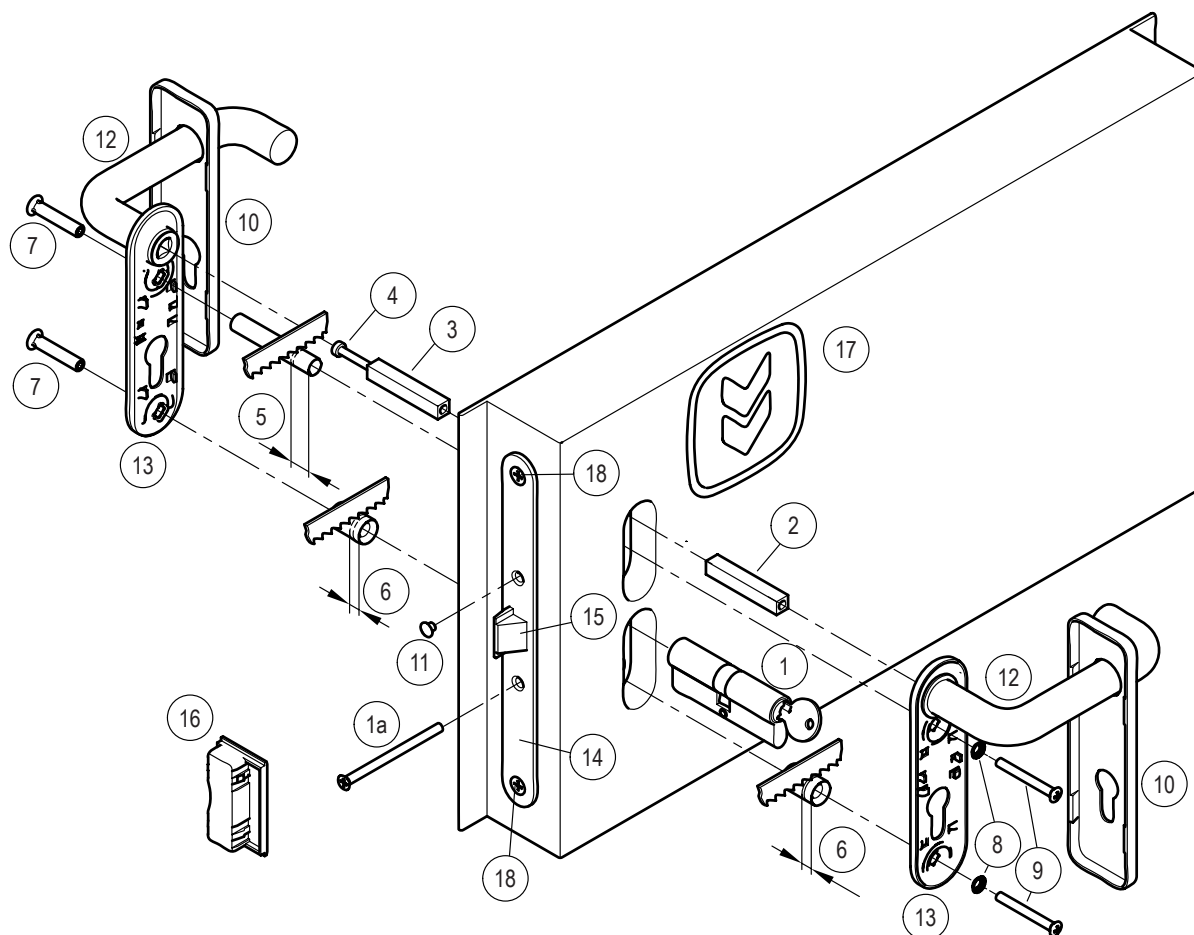

#### CONTENTS OF THE M3 EMERGENCY DEVICE PACKAGE

position	pcs.	description	position	pcs.	description
1, 1a	01	Double nickel-plated cylinder with three keys and fastening screw	9	02	M5x45mm countersunk pan head screw
2, 3	01	Threaded square spindle 9x9x(55+55)mm	10	02	Cover for external plate
4	01	M5 screw for threaded square spindle	11	01	Black cap hole Ø8,8mm
5	01	Spacer Ø10,3mm	12, 13	02	Handle with galvanized steel installation plate
6	02	Spacer Ø15mm	14	01	Panic safe lock to push (AP 16/18)
7	02	M5 threaded insert	16	01	Proget strike box lock
8	02	Countersunk toothed washer	17	01	Adhesive pictogram (green arrow)
			-	01	Kit M3 handle set installation instructions

 Please note that article 4 of the MD of 03 November 2004 obliges the installer to write up, sign and provide the owner of the activity with a declaration of proper installation that makes explicit reference to the instructions supplied by the exit device manufacturer.

#### TOOLS REQUIRED

Medium-sized Philips-head screwdriver or electric screwdriver, fine-toothed hack-saw.

## IMPORTANT

- Installation should be carried out by qualified personnel only and in strict conformity with the instructions supplied.
- For a correct installation all supplied components must be used, including spacers and toothed washers.
-  - No variations are allowed, and only components indicated in the package contents may be used.
- Before proceeding with installation, check the package contents to ensure that no pieces are missing.
- Any different installation configuration from that illustrated on pag. 2/4 is not allowed.

## INSTALLATION



- First disassemble any handles or bar components that are already present.
- Unscrew the two frontal screws (18) and take away the existing lock (14).
- Install the new panic safe lock (14) and fasten it with the same two frontal screws (18).
- Insert the key, bring the cam in the right position and insert the cylinder (1) in the lock (14). Use the screw (1a) to fasten it provisionally; then remove the key.
- Insert the square spindles (2 and 3) into the lock, connect them with the respective screw (4) and tighten the screw. Verify that the latch bolt (15) can be retreated independently from push side and from pull side.
- Adjust the plastic spacers (5 and 6) to the thickness of the leaf so that they do not protrude more than 1mm from it.
- Insert the two threaded inserts (7) in the installation plate of the handle (13), making sure it is well-centred.
- Insert the two spacers (5 and 6) over the threaded inserts (7) and apply the handle on the pull-side of the door, being careful to center the inserts over their respective holes.
- Apply the second handle to the push-side of the door after inserting the screws (9), toothed washers (8) and spacer (6). Center the square spindle, cylinder and screws, starting the screws by hand before fastening them with the screwdriver.
- Use the handles from pull-side and push-side to ensure that the latch bolt (15) of the panic safe lock opens easily and fully.
- Finish fastening the cylinder (1), insert the little cap hole (11) in the open hole of the panic safe lock (14).
- Use the M3 handle to ensure that the latch bolt opens easily and fully; use the same method to check the opening of the latch bolt by using the key. Test the door in both open and closed positions, and if necessary file down the plastic strike box (16).
- Clip the cover plates (10) manually onto the installation plates (13).
- Apply the pictogram (17) with the green arrow on the internal surface of the door, just above the M3 handle.
-  - Lastly, use a dynamometer to measure the force required on the lever of the handle to free the passive leaf from the latch bolt of the lock, from the upper bolt-device and from the lower rod. Record this force measurement in the present document.



## USE

- Ensure that the door always opens easily.
- Avoid unnecessary strains on or handling of the handle.
- Protect the handle from external atmospheric agents.
- Ensure that nothing obstructs free movement of the exit bar.
- Do not paint the lock.
- Use the handle properly, do not pull them in the wrong direction.
- Do not leave the key in the lock.
-  - Make sure that any damaged or malfunctioning parts are replaced immediately.

## MAINTENANCE

To ensure that door usage conforms with regulations, the following maintenance checks should be carried out at least once a month:

- Confirm that all of the installed components correspond with those listed in the present instructions and that no other latching devices than those originally installed have been added to the door.
- Inspect and activate the emergency device to verify that all of its components are in satisfactory operational condition.
- Use a dynamometer to confirm that the release force shows no significant differences from the forces recorded at the time of installation.
-  - Check whether all screws are fully tightened, tightening any that may have loosened.
- Check whether handle and key can be moved with minimal effort, and that the latch bolt retreats from the strike box without offering resistance. If the door has become difficult to open due to friction between the latch bolt and strike box, the resistance can be reduced by filing the strike box down to the appropriate height.
- Ensure that the latch bolt exits completely when the handle is released.
-  - Check whether the inserts and strike boxes are blocked in any way and eliminate any obstructions.
- This product don't requires any special maintenance. Grease should be used to lubricate periodically the internal workings of lock and handle (do not use the spray for the MAC locks).
- For normal cleaning use mild detergents.

-  - Any adjustments that become necessary must be carried out by qualified personnel using original NINZ replacement parts.
-  - The owner of the activity is responsible for keeping the declaration of correct installation on file, conducting proper exit bar maintenance in accordance with all of the manufacturer's maintenance guidelines, keeping maintenance and check-up records and preserving the present document.

<b>ATTESTATO DI CONFORMITÀ</b> DIRETTIVA 89/106/CEE <b>CERTIFICATE OF CONFORMITY</b> DIRETTIVE 89/106/CEE		 0425										
<small>Questo certificato è rilasciato in conformità a quanto prescritto dall'Art.6 par.2 lettera b) del DPR 21 aprile 1993, n° 246 (Direttiva 89/106/CEE) ed attesta la conformità del prodotto di seguito identificato agli Art.1, Art.2 ed allegato A del DPR 21 aprile 1993, n° 246 (Direttiva 89/106/CEE).          This certificate is issued in accordance with the requirements defined in Article 6 par.2 lett. B) of DPR 21st April 1993, n° 246 (89/106/CE Directive) and certifies the compliance of the product to art. 1, art. 2 and annex A of DPR 21th April 1993, n° 246 (89/106/CE Directive).</small>												
<b>ATTESTATO N°</b>	<b>2147 - CPD - 2010</b>	<b>CERTIFICATE N°</b>										
<b>Organismo notificato</b>		<b>Notified Body</b>										
ICIM S.p.A. - Piazza Don Mapelli, 75 - 20099 SESTO SAN GIOVANNI		Identification number: 0425										
<b>Dati Fabbricante</b>		<b>Manufacturer details</b>										
Sede legale NINZ S.p.A. Corso Trento, 2/A 38061 ALA (TN) ITALY		Head office										
Unità operativa		Production unit										
<b>Dati prodotto</b>		<b>Product details</b>										
Tipologia	DISPOSITIVI PER USCITE DI EMERGENZA AZIONATI MEDIANTE MANIGLIA A LEVA O PIASTRA A SPINTA											
<i>EMERGENCY EXIT DEVICES OPERATED BY A LEVER HANDLE OR PUSH PAD</i>												
Denominazione	Dispositivo di emergenza serie "M3" "M3X"	Denomination										
Serrature antipanico	art. AP16/18, 3201001.018, SCA 1 3201001.019/020, MAC 1 3201001.041/042											
Coppia di deviatori	art. 4201010											
Riscontro serratura	art. 2401006, 2401005, 2401015, 2401014, 2401035, 3412001											
Aste verticali	art. 3305013											
Comandi	art. 3101001.009 (M3), 3101017.003 (M3X)											
Sistema di attestazione della conformità		System of attestation of conformity										
Norma di riferimento EN 179:2008		Standard reference										
Classificazione		Classification										
<table border="1" style="border-collapse: collapse;"> <tr> <td style="padding: 2px;">3</td><td style="padding: 2px;">7</td><td style="padding: 2px;">7</td><td style="padding: 2px;">B</td><td style="padding: 2px;">1</td><td style="padding: 2px;">4</td><td style="padding: 2px;">4</td><td style="padding: 2px;">2</td><td style="padding: 2px;">A</td><td style="padding: 2px;">A</td> </tr> </table>		3	7	7	B	1	4	4	2	A	A	
3	7	7	B	1	4	4	2	A	A			
<b>Eventuali estensioni</b>		<b>Extensions</b>										
Nessuna / None												
<b>Eventuali condizioni di subordinazione della Certificazione CE</b>		<b>Condition of subordination of CE certification</b>										
Nessuna / None												
<small>Il presente attestato è valido esclusivamente per il prodotto indicato. Eventuali varianti da apportare devono essere approvate da ICIM SpA          The present certificate is valid only for the product described above. Every change has to be approved by ICIM S.p.A</small>												
<table border="1" style="width: 100%; border-collapse: collapse;"> <tr> <td><b>Data di emissione</b> Issue date</td> <td><b>Emissione corrente</b> Current issue</td> <td><b>Data di scadenza</b> Expiring date</td> </tr> <tr> <td style="text-align: center;">12/03/2010</td> <td style="text-align: center;">12/03/2010</td> <td style="text-align: center;">11/03/2020</td> </tr> </table>		<b>Data di emissione</b> Issue date	<b>Emissione corrente</b> Current issue	<b>Data di scadenza</b> Expiring date	12/03/2010	12/03/2010	11/03/2020	 <b>ICIM S.p.A.</b> Il Presidente Ing. Tullio Badino				
<b>Data di emissione</b> Issue date	<b>Emissione corrente</b> Current issue	<b>Data di scadenza</b> Expiring date										
12/03/2010	12/03/2010	11/03/2020										

SPARE PARTS (see exploded drawing at page. 2/4)

position	code	description
2, 3, 4, 5, 6, 7, 8, 9, 10, 11, 12, 13	3101001.009	Set dual-lever handle
1, 1a	4202101.001	Standard nickel-plated double cylinder 40/40 for Proget and Univer thk60
1, 1a	4202101.002	35/35 for Univer thk50
1, 1a	4202101.003	30/30 for Rever
14	3201001.016	Panic safe lock to push (AP 16/18)
16	4212024.001	Set of 10 Proget strike box lock
16	4212025.001	Set of 10 Univer thk60 strike box lock
16	4212026.001	Set of 10 Univer thk50 strike box lock
16	4212027.001	Set of 10 Rever strike box lock

FOR REPLACEMENTS USE ORIGINAL NINZ REPLACEMENT PARTS FROM ITS FULL CERTIFIED SYSTEM ONLY!

**PROPER DISASSEMBLY**

When some parts or all of the emergency device needs to be replaced, the general guideline is to reverse the order of the original installation instructions. To replace the lock, all parts of the emergency device in the locking zone must be disassembled, including the cylinder. The lock itself (14) can be removed by unscrewing the two frontal screws.

This operation should be carried out with great care in order not to damage or move the components located inside lock housing!

**Certified components for KIT M3**

- Emergency exit device: serie "M3"
- Panic safe lock: art. AP 16/18, MAC 1 3201001.041/042
- Lock strike box: art. 2401006, 2101005, 2401015, 2401014
- External control: art. 3101001.009 (M3)

date	description of the intervention	release force checked	operator

These instructions should be given to the owner of the activity, who shall preserve them as a record of the maintenance operations carried out on the panic exit device.