

- 1) Identification code: **EMERGENCY EXIT DEVICE model M3 TIR**
- 2) Identification number: 4203201.031 KIT M3tir/MAC3 for leaf thick. 60mm
4203201.032 KIT M3tir/MAC3 for leaf thick. 50mm
4203201.033 KIT M3tir/MAC3 for leaf thick. 40mm
4203201.041 KIT M3tir/MAC3 FAILSAFE I.t. 60mm
4203201.042 KIT M3tir/MAC3 FAILSAFE I.t. 50mm
4203201.043 KIT M3tir/MAC3 FAILSAFE I.t. 40mm
- 3) Intended product use: Emergency exit device for escape routes suitable for one-leaved doors or for the active leaf of two-leaved doors with dimensions up to 1350x2880mm/leaf, mass up to 300kg/leaf, mounted on hinges or pivots, with fire resistance up to EI₂120 - REI120 and smoke proof. Projection of the handle 67mm.
- 4) Manufacturer: NINZ S.p.A. - corso Trento 2/A
I-38061 ALA (TN) www.ninz.it
tel. +39 0464 678300 - fax +39 0464 679025
- 5) Auth. representative: -
- 6) Assessment perf. sys.: system 1
- 7) Harmonized standard: EN 179:2008
- 8) Notified body: ICIM S.p.A. N.B. no. 0425 have issued the certificate of conformity for the factory production control no. 0425 - CPR - 002149.

9) Declared performances:

Essential characteristics	Performance-grade	Paragraph
Category of use	3 - high frequency	7.1
Durability	7 - 200.000 cycles	7.2
Door mass	7 - over 200kg	7.3
Suitability for use on fire/smoke doors	B - suitable	7.4
Safety toward people	1 - for emergency exits	7.5
Corrosion resistance	3 - 96 h (high resist.)	7.6
Security toward goods	4 - 3000N	7.7
Projection of operating element	2 - up to 100mm	7.8
Type of operation	A - lever handle	7.9
Field of door application	D - 1 leaved * door pull	7.10
Dangerous substances	conform	ZA

* or for active leaf of double exit doors provided that the inactive leaf remains normally closed.

10) Emergency devices listed in point 1 and 2 are conform to the performances declared in point 9. This declaration of performance is issued under the exclusive responsibility of the manufacturer listed in point 4.

Signed in the name and on behalf of the manufacturer:



Ninz Karl
legal representative of the NINZ S.p.A.

INSTALLATION, USE AND MAINTENANCE HANDBOOK

A204-GB
5001298/2 - 02/19

SYMBOLS EMPLOYED



CAUTION

Indicates a danger that threatens people and/or material goods. Failure to observe the warnings indicated by this symbol may have serious consequences, such as personal injury and property damage.



ATTENTION

Indicates a danger that threatens material goods. Failure to observe the warnings indicated by this symbol may result in damage to material goods.



NOTICE

Warnings related to important technical aspects.

PRODUCT DESCRIPTION

Emergency device for one-leaved doors or for the active leaf of two-leaved doors located at emergency exits and activated by lever handle. Composed of installation plates and double square spindle in galvanized steel, internal and external lever handle with steel core and cover plate in black plastic, panic safe lock to pull and nickel-plated brass cylinder with three keys.

OPERATION MODE

Only the push side of the door is controlled (handle with LED). With lock key-locked, the access consent is possible via electric impulse (button, badge reader, etc.), which gives power supply to the magnet in case of MAC3 or it turn off in case of MAC3 FAILSAFE, while opening is always possible from the pull side by means of the emergency handle. If the lock is not key-locked, opening is always possible, even from the push side.

Door opening in case of power failure (LED off): from the push side the door cannot be opened if the panic safe lock is closed by key whereas opening is possible from the pull side at any time by using the lever handle.

Timed function: the handle activation is controlled by a timed electric impulse to the lock, time duration fixed 30 sec., after of which the handle is disabled consequently. The electric consent is possible by: unlocking button, "Access" code keypad, card-based control system and biometric fingerprint reader (not supplied). Continuous "day time" function: in this mode the handle is continuously enabled by an electric switch (not supplied) for a longer period (for example during the

day), which keeps the lock always enabled. While the handle is enabled the green LED is always ON.

WARNINGS

The M3 TIR handle for emergency exit is intended for the installation on doors to used by people that are accustomed to use the controls of the panic devices for escape routes. Therefore their use is suitable when a panic situation is very unlikely. The safety features of this product are of fundamental importance to ensure its conformity with EN 179. It is strictly forbidden to introduce any type of modifications apart from those described in these installation instructions.

RECOMMENDATIONS

To ensure high level of human safety and appropriate safety levels for material goods, the handle for emergency exit must be installed on doors and door-frames that are in good conditions. The installation of the door itself, therefore, should be checked to ensure that it was installed properly and that nothing obstructs its normal movement.

If rebate sealing are mounted on the door, make sure they do not inhibit proper functioning of the emergency exit device.

The fastening instructions in the present document should be followed scrupulously during installation. Once installation is complete, the installer should give this document to the owner of the activity.

For securing the door in the closed position, do not employ any other latching devices than those specified in the present document. This does not preclude the installation of automatic closing devices.

The M3 TIR emergency device is also designed for installation on hollow metal doors with an internal cell structure.

If a door closer is needed to return the door to the closed position, care should be taken not to make the opening step more difficult for children, the elderly and the disabled.

A pictogram (arrow) should be positioned immediately above the handle activation lever on the internal side of the door.



All of the included components described herein must be positioned and mounted in conformity with the present document.

Any cylinder supplied by the customer must comply with DIN standard 18254.

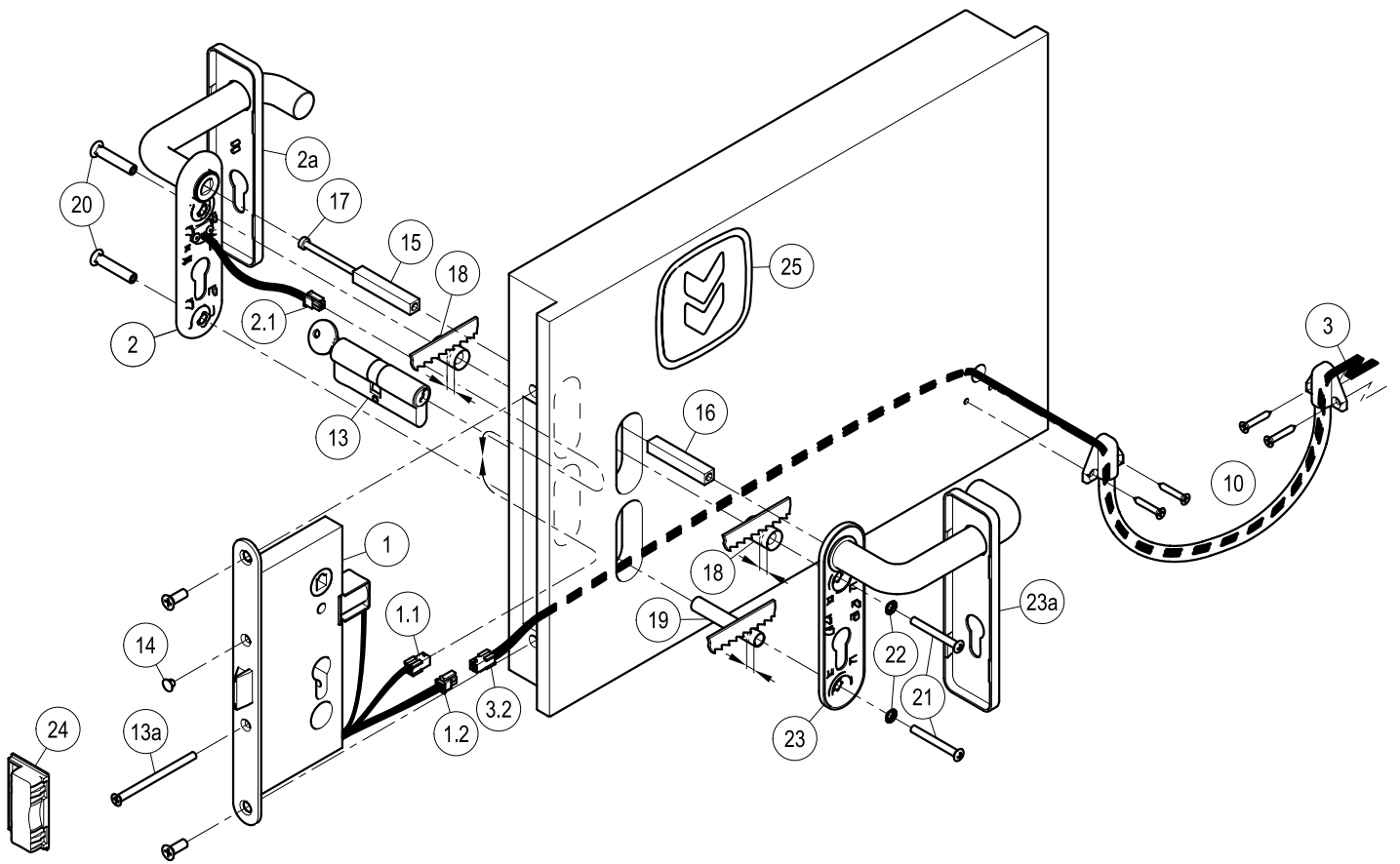

CONTENTS OF THE M3 TIR-MAC3 KIT EMERGENCY EXIT PACKAGE

position	pcs.	description	position	pcs.	description
1	01	MAC3 panic safe lock to pull with magnet and fixed timer of 30 sec.	18	02	Ø15,0x23,5mm spacer
2, 2a	01	Black plastic handle and cover plate, with galvanized steel installation plate and red/green LED applied	19	01	Ø10,3x60,6mm spacer
3	01	Four wire power supply cable (black, red, brown and blue) with connector	20	02	M5 threaded insert
10	01	Nickel-plated flexible cable sleeve L50cm. with fastening screws for power supply cable	21	02	M5x45mm countersunk pan head screw
13, 13a	01	Double nickel-plated cylinder with three keys and M5x85mm fastening screw	22	02	Countersunk toothed washer
14	01	Black cap hole Ø8,8mm	23, 23a	01	Black plastic handle and cover plate with galvanized steel installation plate
15, 16	01	Threaded square spindle 9x9x(55+55)mm	24	01	Proget strike box lock
17	01	M5 screw for threaded square spindle	25	01	Adhesive pictogram (green arrow)
			-	01	M3tir/MAC3 kit handle set installation instructions

 Please note that article 4 of the MD of 03 November 2004 obliges the installer to write up, sign and provide the owner of the activity with a declaration of proper installation that makes explicit reference to the instructions supplied by the exit device manufacturer.

NOTE: any command and supply accessories must be ordered separately; the power wires to the power supply cable (3) must be supplied by the customer, must have a section of 0,75-1,0mm² and of flexible type.

TOOLS REQUIRED

Medium-sized Philips-head screwdriver or electric screwdriver, electric drill with Ø2mm drill bit for steel, fine-toothed hack-saw.

MAC3 TECHNICAL DATA

- Lock **CE** marked in accordance with EN 12209: 2003/AC:2005
- Certificate Nr. 0497/CPD/4265/11
- Notified body 0497
- Power supply 12 or 24 VAC/VDC ±10%
- Absorptions:
 - at 12 V the start-up current is of 500 mA for the firsts 5-6 sec., before changing to a fixed current absorption of a 250 mA;
 - at 24 V the start-up current is of 1 A for 300 millise., before changing to 500 mA for 4-5 sec. and sets then to a fixed current absorption of 250 mA for the remaining time
- Timer incorporated with fixed time of 30 sec.
- Possibility of continuous power supply ("day time" function)
- Ready for possible remote LED (not supplied) with max absorption of 20 mA, for remote signalling of the activation/deactivation of the lock

SIGNALLING ON THE DOOR

The system status is signalled by two LED placed on the installation plate. The green LED signals that the door is not locked, whereas the red indicates that the door is locked. Both LED are off when no power is being supplied.

REMOTE SIGNALLING

A fourth wire can bring an optionally remote signal, to a control unit indicating the activation of the handle. In case of continuous "day time" function, the remote signalling is always active until the power supply is switched off. In case of timed function the remote signal is active for 30 sec.

IMPORTANT

- Installation should be carried out by qualified personnel only and in strict conformity with the instructions supplied.
- For a correct installation all supplied components must be used, including spacers and toothed washers.



- No variations are allowed, and only components indicated in the package contents may be used.
 - Before proceeding with installation, check the package contents to ensure that no pieces are missing and that the opening direction of the door corresponds with that of the lock included in the kit.
 - Any different installation configuration from that illustrated on page 2/5 is not allowed.
 - In case of power failure, from the side of the handle with LED the door can be opened only by key with the MAC system, while the door can be opened at any time with the MAC FAILSAFE system.
- The installation instructions and the wiring diagram are the same for both systems.



- For a regular operation and in order to avoid efforts on the lock, the space between the door-leaf and the catch must be $\geq 6\text{mm}$.

INSTALLATION

- First disassemble any handles components that are already present.
- Unscrew the two frontal screws and take away the existing lock.
- Prepare the path for the power supply cable (3) from the inside of the lock compartment to the power supply wires.



- This operation should be carried out with great care in order not to damage or move the components located inside lock housing!
- Plug the (3.2) connector of the power supply cable (3) in the (1.2) connector of the lock (1), be careful that the pawl of the male connector matches with the latch of the female connector.
- Install the new panic safe lock (1) supplied in the M3tir/MAC3 kit, with the hole for the square spindle (15 and 16) turned upward, letting out the connector (1.1) from lower slot of the push side of the door. Reuse the two frontal screws for the fastening of the panic safe lock.
- Insert the (2.1) connector of the E handle (2) from the upper to the lower slot of the push side of the door, plug it in the (1.1) connector of the lock (1). Be careful that the pawl of the male connector matches with the latch of the female connector.
- Insert the key, rotate the cam in vertical position and insert the cylinder (13) into lock (1). Use the supplied M5x85mm screw (13a) to fasten it provisionally; then remove the key. Warning: do not to use screws with different length.
- Insert the square spindles (15 and 16) into the lock for connecting them by tightening the respective screw (17).
- Adjust the plastic spacers (18 and 19) to the thickness of the leaf so that they do not protrude more than 1mm from it.
- Insert the two threaded inserts (20) in the installation plate of the E handle (2), making sure that they are well-centred.
- Insert the two spacers (18 and 19) over the threaded inserts (20) and apply the E handle (2) on the push-side of the door, being careful to center the square spindle (15) and the inserts over their respective holes.
- Apply the second handle (23) to the pull-side of the door after inserting the screws (21), toothed washers (22) and spacer (18). Center the square spindle, cylinder and screws, starting the screws by hand before fastening them with the screwdriver, avoiding any deformation of the installation plates.
- Use the handle (23) from pull-side of the door to ensure that the latch bolt of the panic safe lock (1) opens easily and fully.
- Finish fastening of the cylinder (13), insert the little cap hole (14) in the open hole of the panic safe lock (1).
- Insert the power supply cable (3) through the flexible cable sleeve (10), fasten it at the leaf of the door using the supplied screw, after drilling holes in the metal panel with the $\varnothing 2\text{mm}$ drill bit.
- Install the strike box lock (24) supplied with the kit onto doorframe of the door, being careful that it match with the latch of the lock.





- When the door is provided with FF rebate sealing, the strike box lock (24) must be filed just enough so the door opens without any effort.

- Carry out the electrical connection as shown on the next page, respecting the correct polarity for the direct current power supply (DC). Finish fastening of the flexible cable sleeve (10). Close the door by key and verify that the operation corresponds to the M3tir/MAC3 system indications. Check the timed or continuous "day time" functions.





- Use the M3tir/MAC3 handle to ensure that the latch bolt opens easily and fully; use the same method to check the opening by using the key. Test the door in both open and closed positions, from both sides of the door. If necessary file down the plastic strike box (24), when the opening becomes difficult due to friction.
 - Clip the cover plates (2a and 23a) manually onto their installation plates.
 - Apply the pictogram (25) with the green arrow on the internal surface of the door, just above the handle.
-  - Lastly, use a dynamometer to measure the force required on the lever of the handle to free the lock. Record this force measurement in the present document.

USE

- Ensure that the door always opens easily.
 - Avoid unnecessary strains on or handling of the handle.
 - Protect the handle from external atmospheric agents.
 - Ensure that nothing hinders the free movement of the lever of handle.
 - Do not paint the lock.
 - Use the handle properly, do not pull them in the wrong direction.
 - Do not leave the key in the lock.
-  - Make sure that any damaged or malfunctioning parts are replaced immediately.
-  - A difficult opening of the door or repeated activation of the handle with the red LED turned on, could damage the lock.

MAINTENANCE

To ensure that door usage conforms with regulations, the following maintenance checks should be carried out at least once a month:

- Confirm that all of the installed components correspond with those listed in the present instructions and that no other latching devices than those originally installed have been added to the door.
 - Inspect and activate the emergency handle to verify that all of its components are in satisfactory operational condition.
 - Use a dynamometer to confirm that the release force shows no significant differences from the forces recorded at the time of installation.
-  - Check whether all screws are fully tightened, tightening any that may have loosened.
- Check whether handle and key can be moved with minimal effort, and that the latch bolt of the safe lock retreats from the strike box without offering resistance. If the door has become difficult to open due to friction, the resistance can be reduced by filing the strike box down to the appropriate height.
 - Ensure that the latch bolt exits completely when the handle is released.
-  - Check whether the inserts and strike boxes are blocked in any way and eliminate any obstructions.
- This product don't requires any special maintenance. Grease should be used to lubricate periodically the internal workings of lock and handle (do not use the spray for the MAC locks).
 - For normal cleaning use mild detergents.



- Any adjustments that become necessary must be carried out by qualified personnel using original NINZ replacement parts.



- The owner of the activity is responsible for keeping the declaration of correct installation on file, conducting proper emergency device maintenance in accordance with all of the manufacturer's maintenance guidelines, keeping maintenance and check-up records and preserving the present document.

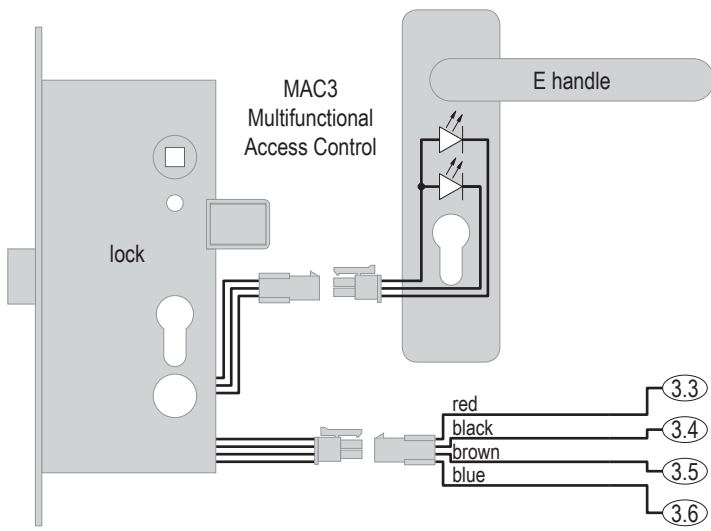

Absorptions:

- 12 V, start-up of 500 mA for 5-6 sec., then 250 mA;
- 24 V, start-up of 1 A for 300 millise., then 500 mA per 4-5 sec., at last 250 mA;
- remote LED max. 20 mA.

Wirings:

- ③.3 + 12/24 VAC/VDC, COM
- ③.4 - 12/24 VAC/VDC (respect polarity with DC)
- ③.5 NO (normally open)
- ③.6 - remote LED (optionally)

wirings with ⑨+⑤		
3.3 + 5f + 9c + 9f	3.4 + 5g + 9g	3.5 + 9d
optional	4a + 5e	4b + 5d
	3.6 + 4d	4c + 5f
	6b + 9b	6c + 9a
⚠	5a → L 230 V ~ - 5b → N 230 V ~ - 5c → ⊥	
	T → keypad	
🕒	0,5' + 30 sec.	

wirings with ⑧		
3.3 + 8c + 8d	3.4 + 8e	3.5 + 8b
optional	4a + 8i	4b + 8h
	3.6 + 4d	4c + 8d
	6b + 8c	6c + 8b
⚠	8k → N 230 V ~ - 8n → L 230 V ~ - 8o → ⊥	
	L.I. → internal badge reader - L.E. → external badge reader	
🕒	1,0' + 30 sec.	

wirings with ⑦+⑤		
3.3 + 5f + 7a	3.4 + 5g	3.5 + 7b
optional	4a + 5e	4b + 5d
	3.6 + 4d	4c + 5f
	6b + 7a	6c + 7b
⚠	5a → L 230 V ~ - 5b → N 230 V ~ - 5c → ⊥	
	Tr. → 230 V ~ → 9 V = adapter	
🕒	30 sec.	

wirings with ⑥+⑤		
3.3 + 5f + 6b	3.4 + 5g	3.5 + 6c
optional	4a + 5e	4b + 5d
	3.6 + 4d	4c + 5f
⚠	5a → L 230 V ~ - 5b → N 230 V ~ - 5c → ⊥	
🕒	30 sec.	

Notes: ' = adjust to minimum timing of ⑨ or ⑧.

Icons:

- ⚠ = attention: danger. Operation to be carried out by qualified personnel;
- ~ = alternating current (a.c.);
- = = direct current (d.c.);
- ⊥ = ground;
- 🕒 = timings.

ATTENTION: with direct current power supply (DC) the polarities must be respected. The power wires must have a maximal section of 0,75-1,0mm² and must be flexible.

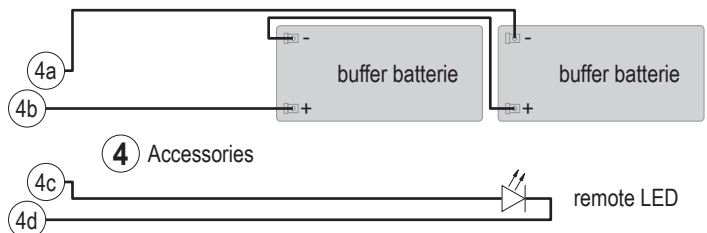
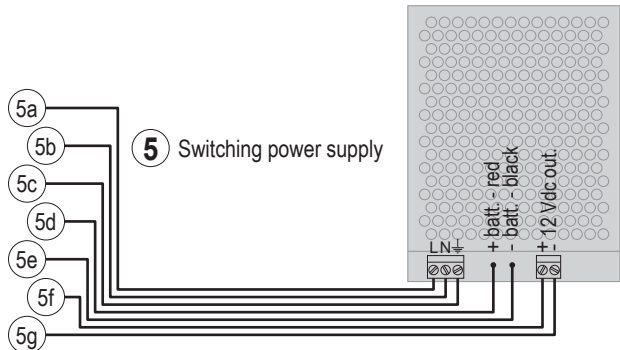
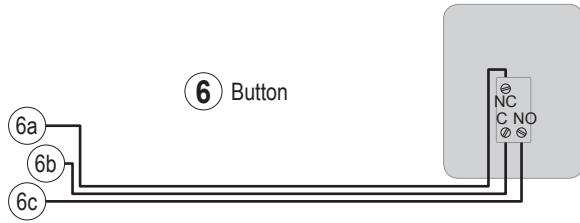
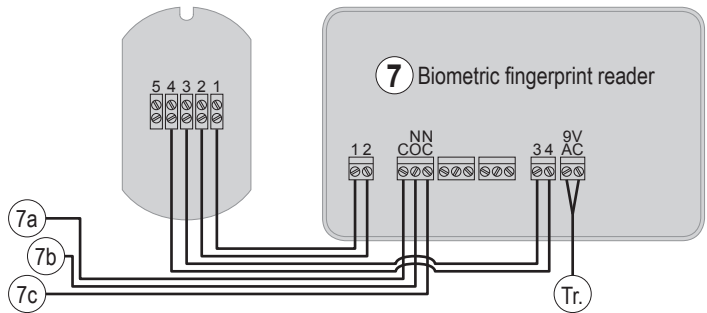
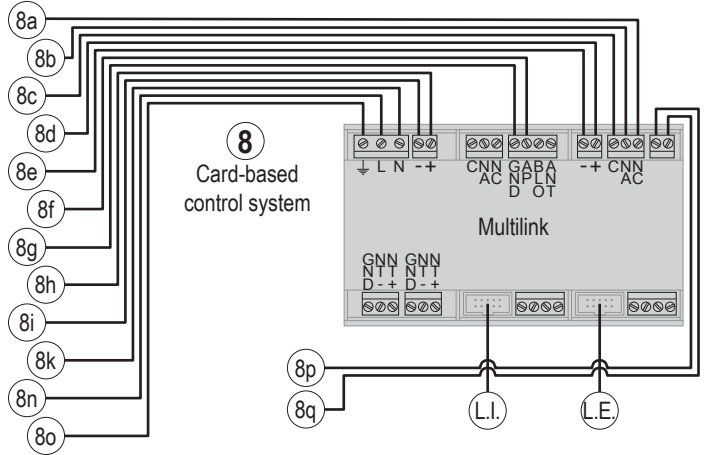
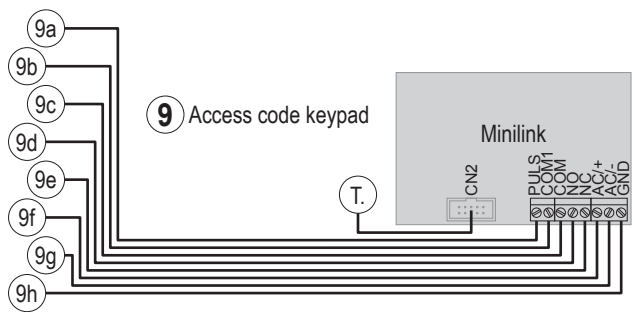



ICIM S.p.A. - Identification number: 0425
Piazza Don Enrico Mapelli, 75 - 20099 Sesto San Giovanni (MI) - ITALY

Certificato di costanza delle prestazioni
Certificate of constancy of performance

Certificato N. **0425 - CPR - 002149**
Certificate No.

In conformità al Regolamento 305/2011/EU del Parlamento Europeo e del Consiglio del 9 marzo 2011 (Regolamento Prodotti da Costruzione o CPR), questo certificato si applica al prodotto da costruzione:
In compliance with Regulation 305/2011/EU of the European Parliament and of the Council of 9 March 2011 (the Construction Products Certification or CPR), this certificate applies to the construction product:

Dispositivi per uscite di emergenza azionati mediante maniglia a leva o piastra a spinta
Emergency exit devices operated by a lever handle or push pad

SERIE / SERIES: **HOT-CIL, HOT-CIL-X
M3 tir, M3X tir**

MODELLI / MODELS: **See annex**

Caratteristiche: vedi Allegato / Characteristics: see Annex

IMMESSO SUL MERCATO CON IL NOME O IL MARCHIO DI
PLACED ON THE MARKET UNDER THE NAME OR TRADE MARK OF
NINZ S.p.A.

SEDE LEGALE / HEAD OFFICE: **Corso Trento, 2/A
38061 ALA (TN) ITALY**

UNITÀ OPERATIVA / PRODUCTION UNIT: **Corso Trento, 2/A
38061 ALA (TN) ITALY**

Questo certificato attesta che tutte le disposizioni riguardanti la valutazione e la verifica della costanza della prestazione e le prestazioni descritte nell'allegato ZA della norma:
This certificate attests that all provisions concerning the assessment and verification of constancy of performance and the performances described in Annex ZA of the standard

EN 179:2008

nell'ambito del sistema 1 di cui al presente certificato vengono applicati e che il controllo di produzione in fabbrica condotto dal produttore è validato al fine di garantirlo.
under system 1 set out in this certificate are applied and that the factory production control conducted by the manufacturer is assessed to ensure the

COSTANZA DELLA PRESTAZIONE DEL PRODOTTO DA COSTRUZIONE
CONSTANCY OF PERFORMANCE OF THE CONSTRUCTION PRODUCT

Questo certificato è stato emesso per la prima volta il 28/04/2010 e ha validità sino a che la norma armonizzata, il prodotto da costruzione, i metodi AVCP o le condizioni di produzione nello stabilimento non subiscano modifiche significative, o sino a che non venga sospeso o ritirato dall'organismo di certificazione notificato ICIM S.p.A.
This certificate was first issued on 28/04/2010 and will remain valid as long as neither the harmonized standard, the construction product, the AVCP methods nor the manufacturing conditions in the plant are modified significantly, unless suspended or withdrawn by the notified product certification body ICIM S.p.A.

Il presente Certificato è da ritenersi valido solo se accompagnato dal relativo Allegato / This Certificate is valid only with the relative Annex

ICIM S.p.A.
Direttore Tecnico

EMISSIONE / ISSUE
15/12/2016

ICIM S.p.A. - Piazza Don Enrico Mapelli, 75 - 20099 Sesto San Giovanni (MI)

SPARE PARTS (see exploded drawing at page 2/5)

position	code	description
1	3201001.049	MAC3 panic safe lock to pull, SX (left)
1	3201001.050	MAC3 panic safe lock to pull, DX (right)
1	3201001.052	MAC3 FAILSAFE panic safe lock to pull, SX (left)
1	3201001.053	MAC3 FAILSAFE panic safe lock to pull, DX (right)
2, 2a, 14, 15, 16, 17, 18, 19, 20, 21, 22, 23, 23a, 25	3101050.011	Set M3 E - black plastic (dual-lever handle with Led)
3	2608016.001	Cable with 4 wires sec. 0,35mm ² L1100mm
3	2608016.002	Cable with 4 wires sec. 0,35mm ² L1450mm
10	2603001.006	Flexible cable sleeve in nickel-plated brass L50cm with silver-plated caps and screws
23, 23a	4202101.004	Standard nickel-plated double cylinder 45/40 for Proget/Univer thickness 60mm
23, 23a	4202101.001	40/40 for Univer thickness 50mm
23, 23a	4202101.002	35/35 for Rever
24	4212024.001	Set of 10 Proget strike box lock
24	4212025.001	Set of 10 Univer thk60 strike box lock
24	4212026.001	Set of 10 Univer thk50 strike box lock
24	4212027.001	Set of 10 Rever strike box lock

 **FOR REPLACEMENTS USE ORIGINAL NINZ REPLACEMENT PARTS FROM ITS FULL CERTIFIED SYSTEM ONLY!**

Certified components for M3tir/MAC3 KIT

- Emergency exit device: model "M3 TIR"
- Panic safe locks: items 3201001.049/050 (MAC3)
- Lock strike boxes: items 2401006, 2401005, 2401015, 2401014
- Operating element: item 3101001.009 (M3)

PROPER DISASSEMBLY
When some parts or all of the emergency device needs to be replaced, the general guideline is to reverse the order of the original installation instructions. To replace the lock, all parts of the handle in the lock zone must be disassembled, including the cylinder. The lock itself (1) can be removed by unscrewing the two frontal screws.

 This operation should be carried out with great care in order not to damage or move the components located inside lock housing!

MAINTENANCE RECORD			
date	description of the intervention	release force checked	operator

 These instructions should be given to the owner of the activity, who shall preserve them as a record of the maintenance operations carried out on the panic exit device.

PROBLEMS	SOLVING
The red LED of the handle is off	<ol style="list-style-type: none"> 1) Check that the connector 1.1 and 2.1 and the connector 3.2 and 1.2 are correctly connected as depicted in page 2 and described in the paragraph "INSTALLATION" of page 3; 2) Check that the lock is properly supplied, as at page 4 depicted (+ 12/24 Vac/dc to the wire 3.3; - 12/24 Vac/dc to the wire 3.4).
The green LED of the handle not switch to on providing the access impulse (consent)	<ol style="list-style-type: none"> 1) Check that the connector 1.1 and 2.1 and the connector 3.2 and 1.2 are correctly connected as depicted in page 2 and described in the paragraph "INSTALLATION" of page 3; 2) Check the electric impulse for access consent of +12/24 Vac/dc on the wire 3.5 (see page 4).
	Verify that are guaranteed the start-up current and the absorption current indicated on page 2 (MAC3 TECHNICAL DATA) and 4 (Absorptions).
The system properly connected and power supplied, does not control the access	Check that the lock is locked by key.
The FAILSAFE lock, while being locked by key, always allows the opening	Check that the lock is properly supplied, as at page 4 depicted (+ 12/24 Vac/dc to the wire 3.3; - 12/24 Vac/dc to the wire 3.4).
The electrical system was executed with 2 wires only (power supply); see the A169-GB instruction in case of replacement of SCA system	<ol style="list-style-type: none"> 1) Connect both the 3.3 (red) and the 3.5 (brown) wires to one wire of electrical power supply (12/24 Vac) or at the positive in case of direct current (+12/24 Vdc); 2) Connect the 3.4 wire (black) with the other power supply wire (12/24 Vac) or at the negative in case of direct current (- 12/24 Vdc). ATTENTION: this connection is possible with MAC locks only (not with MAC FAILSAFE), furthermore the installation of a timer is required. The green LED of the handle (or of both handles) become switch to on only by the electric impulse for the access consent.