



**NINZ S.p.A. - corso Trento, 2/A**  
**I-38061 ALA (TN) / ITALY** [www.ninz.it](http://www.ninz.it)  
**Tel. + 39 0 464 678300**  
**Fax. +39 0 464 679025** [info@ninz.it](mailto:info@ninz.it)

**EXUS LX BMC**  
**PANIC EXIT DEVICE**  
**for emergency exits**

**A225-GB**

5001322/2 - 07/15

Denomination	<b>EXUS LX PANIC EXIT DEVICE</b>	Commercial codes	EXUS LX BMC	item 4201101.148
Name and address of the producer	NINZ S.p.A. - corso Trento 2/A I-38061 ALA (TN) - ITALY	Classification no.	1 <sup>st</sup> Character - grade 3 - Category of use: high frequency 2 <sup>nd</sup> Character - grade 7 - Durability: 200.000 cycles 3 <sup>rd</sup> Character - grade 7 - Mass of the door: over 200kg 4 <sup>th</sup> Character - grade B - Suitable for use on fire/smoke rated doors 5 <sup>th</sup> Character - grade 1 - Safety: suitable for emergency exits 6 <sup>th</sup> Character - grade 3 - Highly resistant to corrosion 96h 7 <sup>th</sup> Character - grade 2 - Safety of goods: 1000N 8 <sup>th</sup> Character - grade 1 - Protrusion of the exit bar: up to 150mm 9 <sup>th</sup> Character - grade A - Activation type: push bar 10 <sup>th</sup> Character - grade A - Suitable for 1 or 2 leaved door	
Year application trademark	2007	Suitable for doors with one leaf or for the active (first opening) leaf of two-leaved doors up to 1350x2880mm/leaf in size, a mass of up to 300kg/leaf, mounted on hinges or pivots, fire resistant up to EI <sub>2</sub> 120 - REI120 and smoke proof. Protrusion of the exit bar: 125mm.		
 Standard	EN 1125:2008			
Certification authority no.	0425			
CE certification no.	0425 CPD 1228			
Classification	3 7 7 B 1 3 2 1 A A			

**SYMBOLS EMPLOYED**



**CAUTION**

Indicates a danger that threatens people and/or material goods. Failure to observe the warnings indicated by this symbol may have serious consequences, such as personal injury and property damage.



**ATTENTION**

Indicates a danger that threatens material goods. Failure to observe the warnings indicated by this symbol may result in damage to material goods.



**NOTICE**

Warnings related to important technical aspects.

**PRODUCT DESCRIPTION**

Panic bar for one-leaved doors or for the active leaf of two-leaved doors located at emergency exits and activated by push-bars. Composed of stainless steel controls, casing, lever and horizontal bar. Stainless steel external lever handle with galvanized steel installation plate.

This product does not contain or release any hazardous materials, as per UNI EN standard no. 1125 appendix ZA.

**OPERATION MODE**

From the pull-side (handle side) the door can be opened at any time whereas from the push-side opening is always possible by using the horizontal bar of the EXUS LX BMC panic exit device.

**WARNINGS**

The EXUS panic bar activated by means of a horizontal bar is intended for use onto doors installed in escape routes where panic situations could develop.

The safety features of this product are of fundamental importance to ensure its conformity with EN 1125. It is strictly forbidden to introduce any type of modifications apart from those described in these installation instructions.

**RECOMMENDATIONS**

In order to ensure that the panic bar could provide a high level of safety toward people and appropriate safety level toward goods, it should only be mounted onto doors and doorframes that are in good conditions. The door itself, therefore, should be checked to ensure that it was installed properly and that nothing obstructs its normal movement.

If rebate sealing are mounted on the door, make sure they do not inhibit proper functioning of the panic bar.



In case of two-leaved door where both leaves are equipped with panic bar, it is mandatory to check that each leaf opens when its respective panic bar is activated, and that leaves open freely when the bars are activated simultaneously.

The fastening instructions in the present document should be followed scrupulously during installation. Once installation is complete, the installer should give this document to the owner of the activity.

The horizontal bar should be installed in a way that maximizes its useable length.

For securing the door in the closed position, do not employ any other latching devices than those specified in the present document. This does not preclude the installation of automatic closing devices.

Different external access devices than those found on the list of certified components on pages 4/4 are considered unacceptable.

The EXUS panic bar is also designed for installation on hollow metal doors with an internal cell structure.

If a door closer is needed to return the door to the closed position, care should be taken not to make the opening step more difficult for children, the elderly and the disabled.

A pictogram (arrow) should be positioned immediately above the horizontal bar on the internal side of the door.



All of the included components described herein must be positioned and mounted in conformity with the present document.

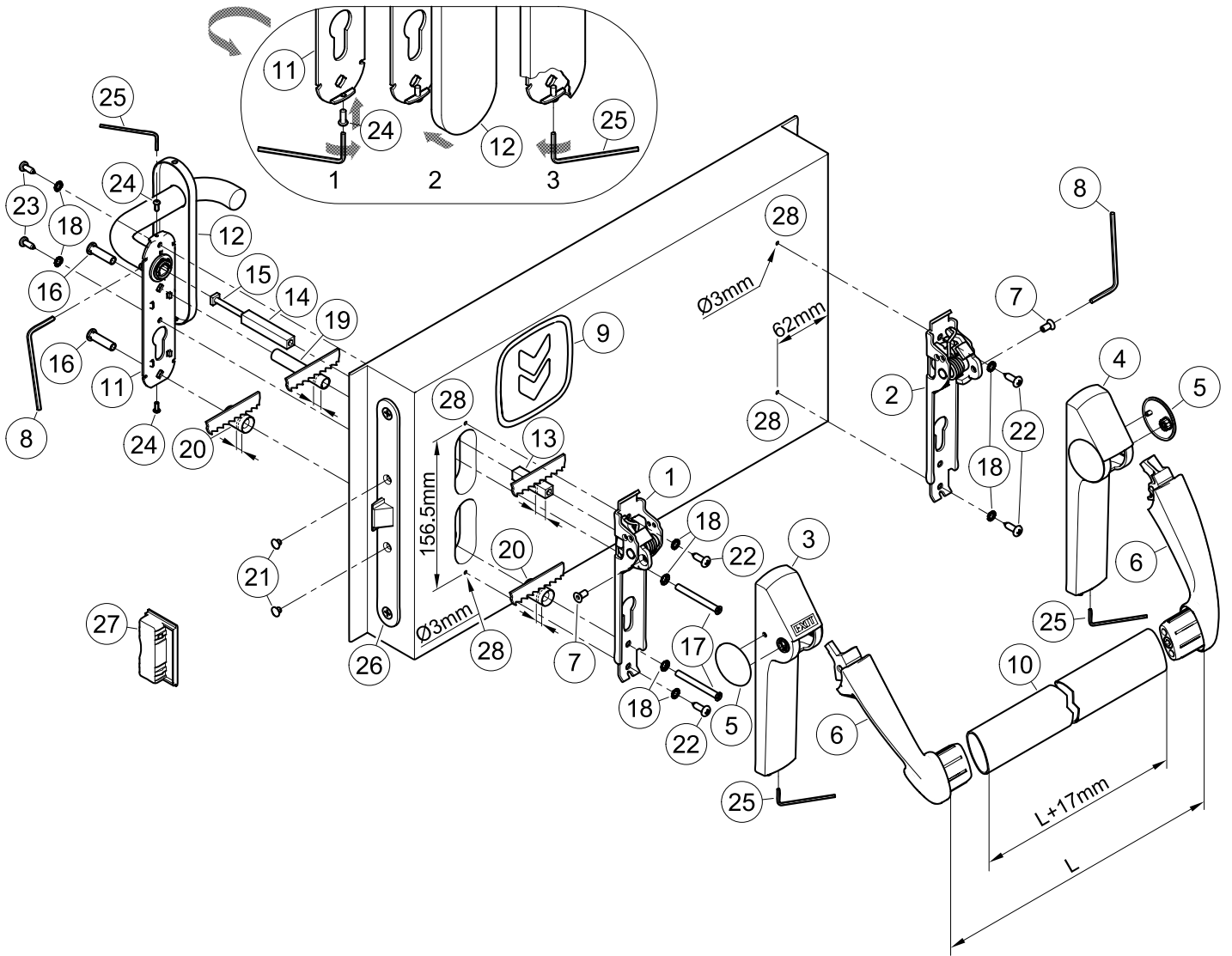

#### CONTENTS OF THE EXUS LX BMC PANIC BAR PACKAGE

position	pcs.	description	position	pcs.	description
1, 2	01	Exus LX mechanism assembly in stainless steel	18	08	Toothed washer
3, 4, 5	01	Exus LX carter set with plugs	19	01	Ø10,3x60,6mm spacer
6	01	Exus LX set carrier arms	20	02	Ø15,0x23,5mm spacer
7	02	M5x10mm hex socket countersunk screw	21	02	Black cap hole Ø8,8mm
8	01	S3 hex key	22	04	Pan head self tapping screw Ø4,8x16mm
9	01	Adhesive pictogram (green arrow)	23	02	Pan head self tapping screw Ø4,2x13mm
10	01	Horizontal bar in stainless steel	24	02	M3x8mm pan head screw
11	01	Stainless steel handle with galvanized steel installation plate and fastening socket set screw	25	01	S2 hex key
12	01	Stainless steel cover plate	-	01	A034 hole-drilling template
13, 14	01	Square spindle 9x9x(55+40)mm	-	01	Exus LX BMC panic bar set installation instruction
15	01	M5 screw for threaded square spindle			
16	02	M5 threaded insert			
17	02	M5x50mm countersunk head screw			

- The panic lock (26) and the respective strike box (counterstrike) (27) are delivered already mounted on the door!

Please note that article 4 of the MD of 03 November 2004 obliges the installer to write up, sign and provide the owner of the activity with a declaration of proper installation that makes explicit reference to the instructions supplied by the exit device manufacturer.

#### TOOLS REQUIRED

Medium-sized Philips-head screwdriver or electric screwdriver, electric drill with Ø2 and Ø3mm drill bit for steel, fine-toothed hack-saw and hack-saw for stainless steel.

## IMPORTANT

- Installation should be carried out by qualified personnel only and in strict conformity with the instructions supplied.
- For a correct installation all supplied components must be used, including spacers and toothed washers.
-  - No variations are allowed, and only components indicated in the package contents may be used.
- Given its purpose, the Exus LX BMC panic bar should be mounted on the push-side of the door.
- Before proceeding with installation, check the package contents to ensure that no pieces are missing.
- Check if the door is equipped with the panic safe lock.
- Check the type of lever handle to apply and follow the specific instructions.
- Any different installation configuration from that illustrated on page 2/4 is not allowed.

## INSTALLATION

- Adjust the plastic spacers (19 and 20) to the thickness of the leaf so that they do not protrude from it.
- Adjust the threaded square spindle (13) to the thickness of the leaf so that it protrudes 11±1mm from the door surface; be careful to cut the bevelled side.
- Insert the square spindles (13 and 14) into the lock for connecting them by tightening the respective screw (15).
- Screw onto installation plate of stainless steel handle (11) the screws (24), just enough to insert the cover plate (12).
- Insert the two threaded inserts (16) in the installation plate of handle (11), making sure that they are well-centred.
- Insert the two spacers (19 and 20) over the threaded inserts and apply the handle on the pull-side of the door, being careful to center the square spindle and the inserts over their respective holes.
- Apply the operating mechanism (1) to the lock side (push-side of the door) after inserting the screws (17), toothed washers (18) and spacer (20). Center the square spindle and screws, starting the screws by hand before fastening them with the screwdriver.
- Use the template to drill the holes (28) with the Ø3mm drill bit, checking the level. If holes are already present, drill them again for the internal reinforcement.
- Fasten the mechanism (1) even more securely with the self-tapping screws Ø4,8x16mm (22) and their toothed washers (18).
- Fasten the mechanism (2) of the panic bar at hinged side, using the self-tapping screws Ø4,8x16mm (22) and their toothed washers (18).
- Remove the externally-facing plugs (5) from both carter (3 and 4). To do this, insert a finger inside the carter and push the plug out, being careful not to remove the plastic insert. Apply the carter with "EXIT" wording (3) on the operating mechanism (1) and the other one (4) on the mechanism from hinged side (2). Do not fasten the socked set screws, so as to let the two carter movable.
- Apply the carrier arms (6) and fasten them with the dedicated screws (7), tightening them securely with the included S3 wrench (8).
- Make a precise "L" measurement, cut the stainless steel bar (10) adding 17mm, and remove the burrs from the cut edge. Remove one carrier arm, attach the bar and re-fasten the entire assembly.
- Finish fastening of the two carter (3 and 4), screw on without overtighten the socked set screw, using the S2 hex key (25), then apply the plugs (5).
- Insert the two caps (21) in the open holes of the panic safe lock (26).

-  - Push the Exus LX BMC panic bar at any point along the horizontal bar, checking to ensure that the latch bolt of the lock opens easily and fully. Use the same method to check the external handle. Test the door in both open and closed positions and if necessary, file down the plastic strike box (27) of one-leaved doors or the panic safe lock for inactive leaf of two-leaved doors.

- Fasten the installation plate of stainless steel handle (11) using the Ø4,2x13mm self-tapping screws (23) and their toothed washers (18) after drilling holes in the metal panel with the Ø2mm drill bit. Insert the cover (12) onto the handle (drw. 2). Using the S2 hex key (25) to unscrew the screws (24) until the cover become fixed, avoiding any deformations (drw. 3). Insert and fasten the socket set screw well with the S3 hex key (8).
- Apply the pictogram (9) with the green arrow on the internal surface of the door, just above the horizontal bar.
-  - Lastly, use a dynamometer to measure the force required on the horizontal bar to release the lock. Record this force measurement in the present document.



## USE



- Ensure that the door always opens easily.
- Avoid unnecessary strains on or handling onto handle and exit bar.
- Protect the panic bar from external atmospheric agents.
- Ensure that nothing hinders the free movement of the horizontal bar.
- Do not paint the lock.
- Use the bar properly, do not pull it in the wrong direction.

-  - Make sure that any damaged or malfunctioning parts are replaced immediately.

## MAINTENANCE

To ensure that door usage conforms with regulations, the following maintenance checks should be carried out at least once a month:

- Confirm that all of the installed components correspond with those listed in the present instructions and that no other latching devices than those originally installed have been added to the door.
- Inspect and activate the panic bar to verify that all of its components are in satisfactory operational condition.
- Use a dynamometer to confirm that the release force shows no significant differences from the forces recorded at the time of installation.
-  - Check whether all screws are fully tightened, tightening any that may have loosened.
- Check whether panic bar and handle can be moved with minimal effort, and that the latch bolt of the safe lock retreats from the strike box without offering resistance. If the door has become difficult to open due to friction, the resistance can be reduced by filing the strike box down to the appropriate height.
- Activate the Exus LX BMC panic bar at both ends of the horizontal bar, checking to ensure full retraction of the latch bolt in both cases.
- Ensure that the latch bolt exits completely when the horizontal bar is released.
- Check the horizontal bar and replace it if any damage or deformities are detected.
-  - Check whether the inserts and strike boxes are blocked in any way and eliminate any obstructions.
- This product requires no special maintenance. Grease spray should be used to lubricate the internal workings of lock, handle and panic bar on a regular basis – the latter has a hole on its carter for this purpose, located below the carrier arms.
- For normal cleaning, use a cleaning agent designed specifically for stainless steel.

-  - Any adjustments that become necessary must be carried out by qualified personnel using original NINZ replacement parts.
-  - The owner of the activity is responsible for keeping the declaration of correct installation on file, conducting proper panic bar maintenance in accordance with all of the manufacturer's maintenance guidelines, keeping maintenance and check-up records and preserving the present document.

 <p><b>ATTESTATO DI CONFORMITÀ</b> DIRETTIVA 89/106/CEE <b>CERTIFICATE OF CONFORMITY</b> DIRETTIVA 89/106/CEE</p> <p>Questo certificato è rilasciato in conformità a quanto prescritto dall'Art.6 par.2 lettera b) del DPR 21 aprile 1993, n°246 (Direttiva 89/106/CEE) ed attesta la conformità del prodotto di seguito identificato agli Art.1, Art.2 ed allegato A del DPR 21 aprile 1993, n°246 (Direttiva 89/106/CEE) This certificate has been issued in conformity to what prescribed by the Art.6 par.2 letter b) of the DPR 21/04/1993, n°246 (Directive 89/106/CEE) and certifies the conformity of the product described below to the Art.1, Art.2 and attachment A of DPR 21/04/1993, n°246 (Directive 89/106/CEE)</p>		
<b>ATTESTATO N°</b>	<b>0425 CPD 1228</b>	<b>CERTIFICATE N°</b>
<b>Organismo notificato</b>	<b>Notified Body</b>	
ICIM S.p.A. - Piazza Don Mapelli, 75 - 20099 Sesto San Giovanni (MI) ITALY	Identification number: 0425	
<b>Dati Fabbricante</b>	<b>Manufacturer</b>	
Sede legale NINZ S.p.A. Corso Trento, 2/A - 38061 ALA (TN) ITALY	Head office	
Unità operativa	Operative unit	
<b>Dati prodotto</b>	<b>Product Type</b>	
Tipologia	<b>DISPOSITIVI ANTIPANICO PER USCITE DI SICUREZZA AZIONATI MEDIANTE UNA BARRA ORIZZONTALE</b>	
	<b>PANIC EXIT DEVICES</b>	
Denominazione	Dispositivo antipanico serie "TWIST" "EXUS LP" "EXUS LA" "EXUS LX".	Denomination
Serrature antipanico	art. AP16/18, SCA 1 3201001.019/020, MAC 1 3201001.041/042, 4506002.17 (V), 3201001.018, 485-65-0, 4506002.22 (V), B18310-02-RL-8 (V), B18370-04-LJ-8 (V), Controserrature antipanico art. AP020P, AP020U, 4506002.18 (V), 3201001.6, 43190-95, B1890.1004 (V).	
Dispositivo superiore	art. 3105080, 3105024, 4506003 (V), 3305003, B1795.0001 (V), B1895.0003 (V).	
Riscontro asta	art. 2401036, 2401046, 2401044, 4506005 (V), 2401002, B9000.0567 (V), B9000.0490 (V).	
Boccola pavimento	art. 2401001, 2401007, 3105091, 4509006 (V), 2401020, 4418008, B9028.0001 (V).	
Deviatori	art. 4201010.	
Aste verticali	art. 3305015, 3305016, 3305002, 4509003 (V), 3305013, 990837, B9006.0014 (V), B9006.0005 (V).	
Riscontro serratura	art. 2401006, 2401005, 2401015, 2401014, 4506006 (V), 2401006, 2401035, 3412001, B9000.0402 (V).	
Comandi esterni	art. BM, BSP, BS, BMC, BC, B, A, BM inox, BM alu, BSP inox, BSP alu.	
Sistema di attestazione della conformità	1	Attestation of conformity
Norma di riferimento	EN1125:2008	Standard
Classificazione	3   7   7   B   1   3   2   1   A   A	Classification
<b>Eventuali estensioni</b>	Nessuna / None	<b>Extensions</b>
<b>Eventuali condizioni di subordine della Certificazione CE</b>	Nessuna / None	<b>Possible conditions of subordination of the CE Certification</b>
<p>Il presente attestato è valido esclusivamente per il prodotto indicato. Eventuali varianti da apportare devono essere approvate da ICIM S.p.A. The present issue is valid only for the product described above. Possible changes to have to be approved by ICIM S.p.A.</p>		
<b>Data di emissione</b> First issue	<b>Emissione corrente</b> Current issue	<b>Data di scadenza</b> Expiring date
18/04/2007	26/06/2013	17/04/2017
		

SPARE PARTS (see exploded drawing at page 2/4)

position	code	description
1, 2, 3, 4, 5, 6, 7, 8, 9	3102061.001	Exus LX latch case – stainless steel
1, 2	3105127.001	Exus LX assembly mechanism – stainless steel
3, 4, 5	3105163.001	Exus LX carter set with plugs
6	3105140.001	Exus LX set carrier arm
7, 8	3105026.001	Twist/Exus bag
10	4204016.001	Stainless steel bar set
8, 11, 12, 13, 14, 15, 16, 17, 18, 19, 20, 21, 22, 23, 24, 25	4211101.024	Twist/Exus BMC set - stainless steel
26	3201001.016	Panic safe lock to push (AP 16/18)
27	4212024.001	Set of 10 Proget strike box lock
27	4212025.001	Set of 10 Univer thk60 strike box lock
27	4212026.001	Set of 10 Univer thk50 strike box lock
27	4212027.001	Set of 10 Rever strike box lock



FOR REPLACEMENTS USE ORIGINAL NINZ REPLACEMENT PARTS FROM ITS FULL CERTIFIED SYSTEM ONLY!

Certified components for EXUS LX BMC

- Panic exit device: model "EXUS LX"
- Panic safe lock: item AP 16/18
- Lock strike boxes: items 2401006, 2401005, 2401015, 2401014
- Operating element: item BMC inox

PROPER DISASSEMBLY

When some parts or all of the panic bar needs to be replaced, the general guideline is to reverse the order of the original installation instructions. To replace the lock, all parts of the panic bar in the locking device zone must be disassembled, including the external handle. The lock itself (26) can be removed by unscrewing the two frontal screws.



This operation should be carried out with great care in order not to damage or move the components located inside lock housing!

date	description of the intervention	release force checked	operator