

INSTRUCTIONS FOR INSTALLATION, USE AND MAINTENANCE OF ELECTROMAGNETS

N.
0805/1345

IE03-GB
5012008/2 - 12/12

EM

Rev. 2
04/12/12

CE	13	0407-CPD-011(IG-098-2004)/04	UNI EN 1155:2003	3	8	7	1	1	3
		OPERA s.r.l. - 41122 MODENA - Via Portogallo, 43							

Electromagnet suitable for revolving doors, fire and/or smoke resistant.

Number	Characteristic	Description
1st	Utilisation category	grade 3: door for public use or other users who have no particular incentive to take care, that is, possibly incorrect use of the door.
2nd	Durability	grade 8: 500,000 test cycles.
3rd	Mass of the test door	Suitable for use with door closing devices having a power range from 3 to 7 . grade 3: 60Kg. grade 7: 160Kg.
4th	Fire resistance	grade 1: suitable for use on flame/smoke resistant doors, provided the contribution to fire resistance of the electromagnetic doorstop to the specified flame/smoke arresting door as a whole is satisfactorily determined.
5th	Safety	grade 1: use of all doorstop devices must meet essential safety requirements
6th	Resistance to corrosion	grade 3: high resistance.

TECHNICAL CHARACTERISTICS

Dimensions mm.	Power supply	Current Absorption	Holding force	Release button	Anti-disturbance varistor	Anti-magnetism extractor
75x90x35	24 Vdc	60 mA	> 55 Kg	YES	YES	YES

OPERATION

Once powered, the electromagnet attracts its counterplate.
By pushing the release button, power is removed from the electromagnet, thereby releasing the counterplate and allowing the door to be closed.

WARNING

The holding magnet for fire arresting doors and its counterplate are CE certified in accordance with European standards UNI EN-50081-1, UNI EN-50082-1 and UNI EN-1155.
No type of modification is permitted, with the exception of those described in these instructions.

The electromagnet is designed for indoor installation and should not be exposed to outdoor elements.
Installation must be carried out in strict adherence to the following instructions.
All of the components included must be installed for correct operation.
Installation, as well as any adjustments or maintenance, must be performed by specialised personnel.
This product does not contain any hazardous substances as required by standard UNI EN-1155 appendix ZA.

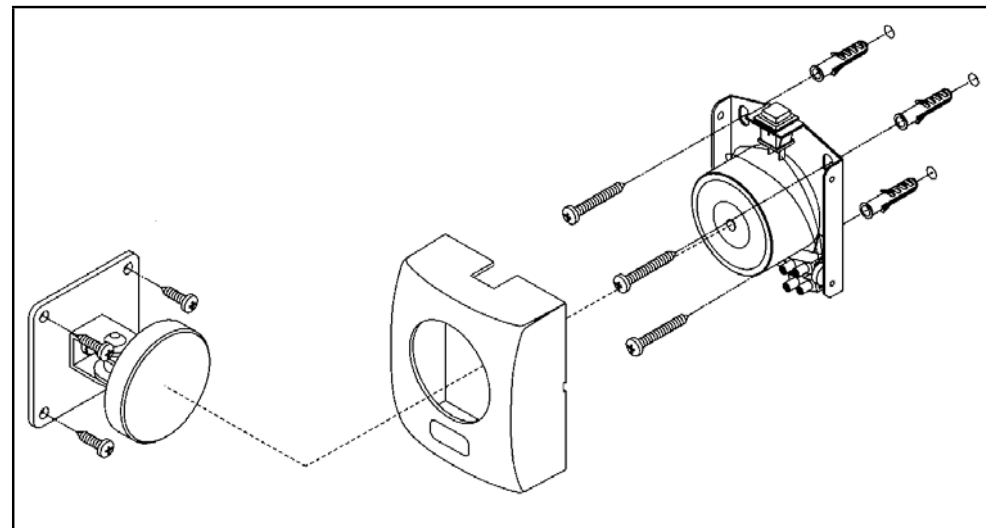

CONNECTION DIAGRAM

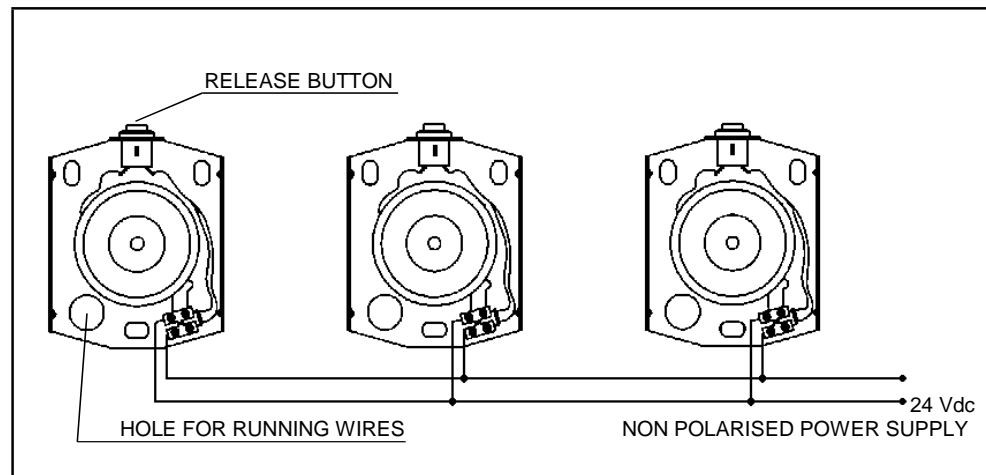

PACKAGE CONTENTS

- 1 electromagnet with release button and ABS covering.
- 1 galvanised swivel counterplate.
- mounting screws kit: N°3 4.2x30 screws and N°3 plugs for installation of the electromagnet; N°4 4.2x16 screws for installation of the counterplate.
- Installation and maintenance instructions.

SPARE PARTS

Galvanised swivel counterplate with base art. 01805Z.

INSTALLATION

Select the position for the electromagnet (wall with access to 24Vdc power supply) and the counterplate (door).

The counterplate should be affixed to the pull side of the door, preferably on the top part of the free corner, approximately 200mm from the edges.

The electromagnet should remain on the wall, perfectly coinciding opposite the counterplate.

Once the physical feasibility of this positioning has been ascertained, proceed with the following steps:

Fixing of the electromagnet:

1. Remove the ABS cover.
2. Place the electromagnet on the wall, pointing the red button toward the most easily accessible side. Trace the 3 screw holes with a pencil and remove the electromagnet.
3. Drill 3 holes 35mm deep with a Ø6mm bit.
4. Place the 3 included plugs in the holes and attach the electromagnet using the Ø4.2x32mm screws. The screw holes are oblong in order to allow the electromagnet to be levelled.
5. Connect the electrical wires according to the diagram.
6. Reassemble the ABS cover.

Installation of the counterplate:

1. Apply power to the electromagnet and place the counterplate on it. Using the release button, adjust the position of the counterplate.
2. Open the door so that it rests against the base of the counterplate.
Determine the position of the counterplate and trace the 4 screw holes on the door with a pencil. Remove the counterplate.
3. Using a Ø3mm bit, drill the 4 holes which are marked.
Attention: the holes should not go the whole way through.
4. Attach the counterplate using the included 4.2x16 screws.

Testing

Open the door and verify that it is held open. Press the red button to close the door.

INSTRUCTIONS FOR USE

Open the door and verify that it is held open.

To close the door, press the red button.

Attention: do not pull on the door before having pushed the button or powering down the magnet.

MAINTENANCE

Regular preventive maintenance is recommended at least once a month to verify that all of the components are in satisfactory working condition. In particular:

- Check that the door is held open by the electromagnet. If this is not the case, ensure that: the power supply is correct; that the contact surface is smooth and that all of the magnetic part of the electromagnet is covered by the counterplate; that there are no objects blocking the perfect contact of the counterplate with the electromagnet (paint, dirt, rust, etc.).
- Verify the correct operation of the release button.
- Make sure the mounting screws are sufficiently tight.

The instructions and all maintenance indications must be delivered to the end user by the installer.

DECLARATION OF PERFORMANCE N. 1592/2014
According to CPR 305/2011

1. UNIQUE IDENTIFICATION CODE OF THE PRODUCT-TYPE: Wall-mounting electromagnet
2. TYPE, BATCH OR SERIAL NUMBER ALLOWING IDENTIFICATION OF THE CONSTRUCTION PRODUCT AS REQUIRED UNDER ARTICLE 11 (4) OF THE CPR: 19001BNZ
3. INTENDED USE OF THE CONSTRUCTION PRODUCT AS FORESEEN BY THE MANUFACTURER: **DOOR HOLDER ELECTROMAGNETIC DEVICE FOR FIRE DOORS TO MATCH WITH COUNTER PLATES 01800Z OR 01805Z ONLY**
4. NAME AND ADDRESS OF THE MANUFACTURER: **OPERA S.r.l. - VIA PORTOGALLO, 43 – 41122 MODENA - ITALY**
5. NAME AND CONTACT ADDRESS OF THE AUTHORIZED REPRESENTATIVE WHERE APPLICABLE: ---
6. SYSTEM OF ASSESSMENT AND VERIFICATION OF CONSTANCY OF PERFORMANCE OF THE CONSTRUCTION PRODUCT:
7. NAME AND IDENTIFICATION NUMBER OF THE NOTIFIED BODY: **ISTITUTO GIORDANO – Notified body CE N. 407**
8. DECLARED PERFORMANCE : **EN 1155:1997/ A1:2002/AC:2006**

ESSENTIAL CHARACTERISTICS	PERFORMANCE	HARMONISED TECHNICAL SPECIFICATION
CATEGORY OF USE	Suitable for use on fire/smoke door assemblies, subject to satisfactory assessment of the contribution of the electrically powered hold-open device to the resistance of specified fire/smoke door assemblies	5.2.13
DURABILITY	50.000 Test cycles - The product has been tested until 500.000 cycles	5.2.4
DOOR HOLDER FORCE	From DIGIT 3 to DIGIT 7 - Digit 3: 60Kg - Digit 7: 160KG	EN 1155:1997/ A1:2002/AC:2006
SUITABILITY FOR USE ON FIRE / SMOKE COMPARTMENTATION DOORS	Suitable for use on Fire/Smoke door assemblies	EN 1155:1997/ A1:2002/AC:2006
SAFETY	DIGIT 1 – All electrically powered door holder devices are required to satisfy the essential requirement of safety in use	EN 1155:1997/ A1:2002/AC:2006
CORROSION RESISTANCE	High Resistance	5.2.14.1 5.2.14.2

DECLARATION OF PERFORMANCE

The performance of the product identified in points 1 and 2 is in conformity with the declared performance in point 8. This declaration of performance is issued under the responsibility of the manufacturer identified in point 4

Opera S.r.l.
www.opera-italy.com