

# INSTALLATION, USE AND MAINTENANCE HANDBOOK FOR REI120 FIRE-RATED PROGET DOORS – INSTALLATION ONTO PLASTERBOARD WITH EMBRACING FRAME

Homologation no. BZ050REI120P026F1

164-GB

5001501/2 - 06/13

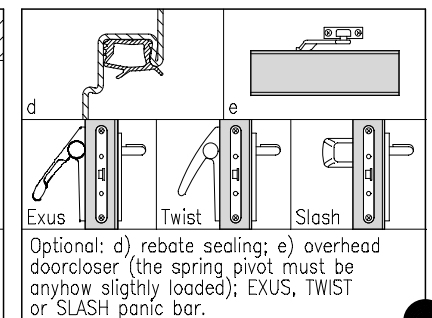
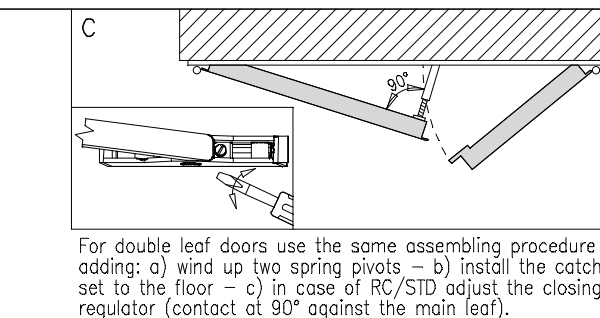
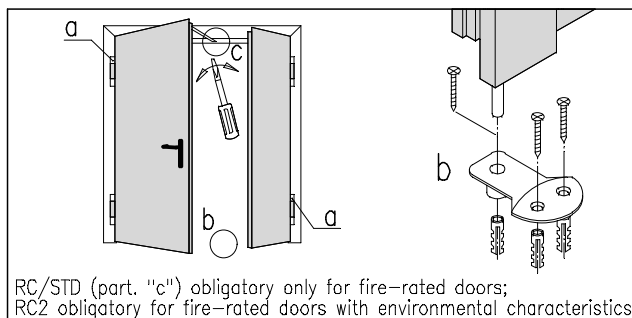
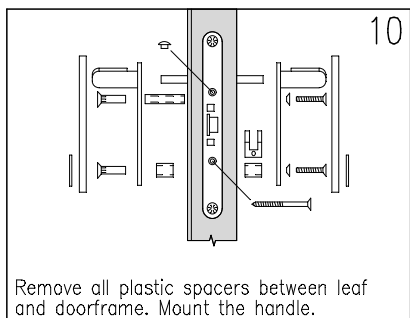
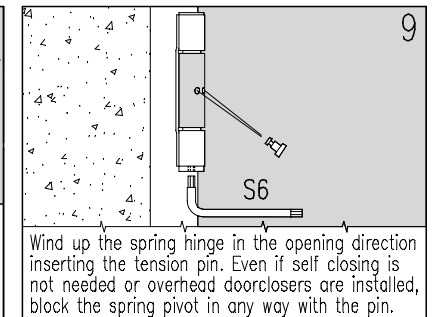
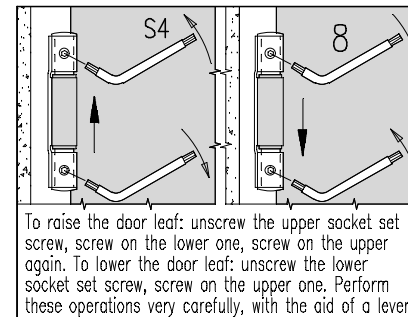
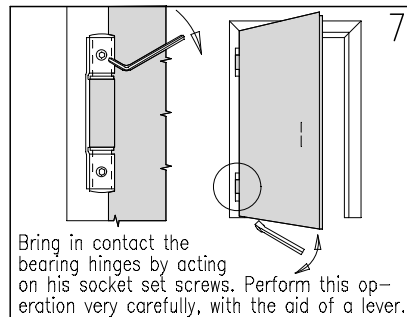
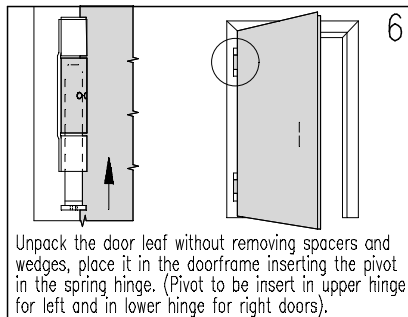
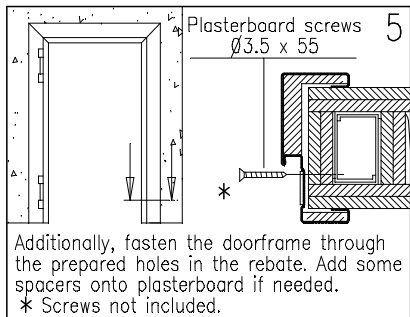
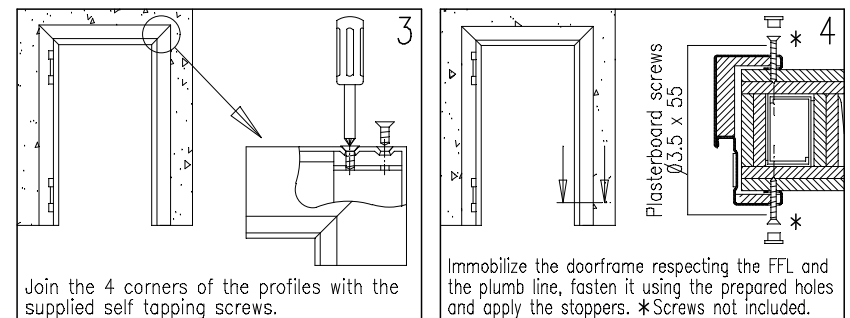
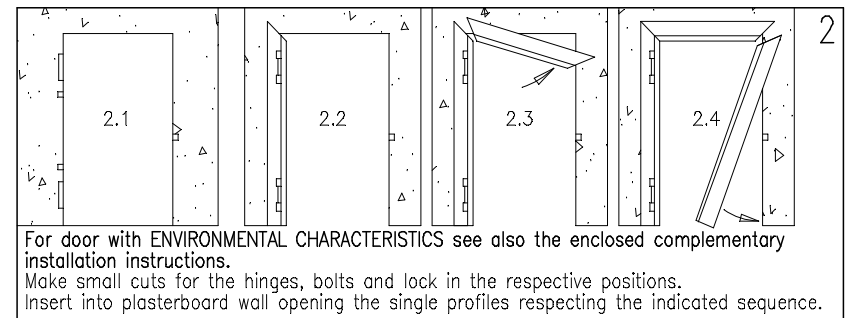
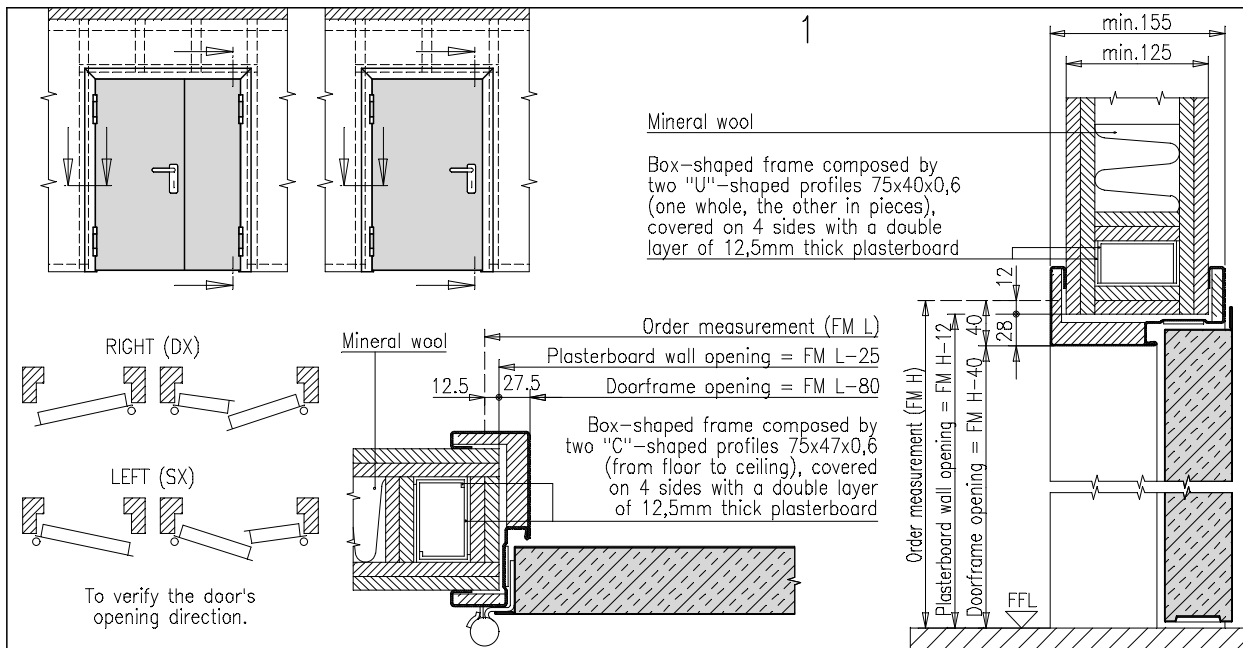

# INSTALLATION, USE AND MAINTENANCE HANDBOOK FOR REI120 FIRE-RATED PROGET DOORS – INSTALLATION ONTO PLASTERBOARD WITH EMBRACING FRAME

164-GB

## GENERAL NOTES

**STANDARD:** the assemble instructions have to be followed in every detail to respect the test conditions and assure the perfect functioning of the door, including the self-closing. Furthermore a regular service is necessary.

**LIABILITY:** it is duty of the installer to follow the installation instructions in any detail, specifically point 7, 8 and 9, in order to guarantee the safety of the end-users.

**PLASTERBOARD PARTITIONS:** it is duty of the buyer to build the partitions to comply with the present assembling instructions and to take any precaution to avoid mechanical resistance loss in case of partitions higher than 2700 mm.

**FINISHING:** the serial door is finished with an epoxy-polyester powder paint oven-baked at 180 ° C. The surface is orange-skin and particularly resistant. In case an additional paint is desired we advise to follow these instructions:  
 – make smooth the surfaces with sandpaper and dust them;  
 – give a first hand of opaque 2 components epoxide using the product ALCEA EPOX 5203 / 0059 (beige);  
 – finish the surfaces with enamels or paints to your choice.

**CLEANING:** the doors are supplied from the factory clean and packed. We suggest to use a clothe and soaped water only. Do not scratch the surfaces.

**WARRANTY:** the manufacturer gives warranty as per Italian law (C.C.1495). Any claim for missing or damaged goods have to be recorded by inserting a written remark in the delivery notes and must be notified the maximum within eight days from the date of materials receipt.

## CURRENT CE MARKED ACCESSORIES:

Std015 lock:	<b>CE</b> 0497/CPD/4265/11	– EN 12209:2003/AC	– 3 M 3 1 0 C 2 H A 2 0
Hinges:	<b>CE</b> 0789-CPD-2005	– EN 1935:2004	– 4 7 7 1 1 4 0 14
RC/STD closing regulator:	<b>CE</b> CPD-0425-1153	– EN 1158:2003	– 3 5 5/3 1 1 4

The **CE** marking of the Std 019 lock for inactive leaf of two-leaved doors is only valid if a panic bar or emergency handle is installed onto main leaf.

## USE AND MAINTENANCE INSTRUCTIONS FOR PROGET FIRE-RATED DOORS

All fire-rated doors need regular maintenance in order to verify that no damage occurred and that they close regularly. The scheduled maintenance shall guarantee that the leaf swings correctly and that the self closing mechanism works properly. Doors must be kept free from obstructions.

Any 5.000 opening cycles but at least every 6 months the following operations shall be carried out:

- lubricating the ball-bearing hinges;
- lubricating the spring hinges and the springs after removing the tension pins.
- wind up the springs inserting the tension pins. Verify that the closing force is sufficient to shut the door if opened to  $30 \pm 2^\circ$ ;
- lubricating the lock and the latch.

For double leaf doorsets additional controls shall be carried out:

- verify the functionality of the secondary leaf's rods and lubricate its guide rail;
- clean the hole of the floor catch set;
- lubricate the lock and the self-locking device (top);
- verify the regular functionality of the closing regulator (in case of RC/STD, the arm must be in perpendicular position to the main leaf).  
Lubricate the mobile parts of the closing regulator.

Verify the regular functionality of the doors accessories (handle, panic bar, overhead doorcloser etc.). Their mobile parts shall be lubricated too.

In case of irregular functioning of the door or its accessories contact an authorized installer or replace the damaged accessories.

N.B.: For lubrication use viscous products.

## HANDLING AND STORAGE – COMPLAINTS

**Handling:** in case of handling with webbing slings/ropes, place them under the feet of the pallet; avoid to place them under the boards; avoid that the action of slings/ropes produces too much pressure upon the doors, by means of spacers interposed in the upper part. Do not handle the leaves using suction caps.

**Storage:** it is duty of the company/person taking over the doors to store them in a suitable place so that they will be protected from the natural agents and from the direct sun rays. If during transportation or truck unloading it rains or snows on the doors it is necessary to remove immediately the nylon film from each leaf and doorframe, put them in vertical position to dry appropriately.

**Complaints:** in case of external visible defects on doors, they have to be marked in the copy of the transportation document to be returned to the forwarder and notified to the manufacturer by registered mail within 48 hours. We remember that according to our general conditions intrinsic defects have to be notified to the manufacturer within 8 days from the delivery date by registered mail. Goods with defects never have be utilised or assembled, they should be stored at disposal for controls by the manufacturer appointed person.

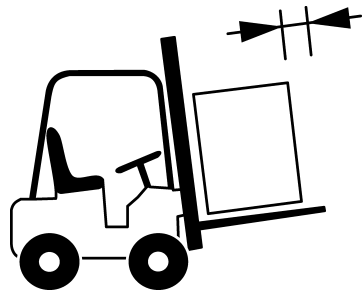

Move the materials with appropriate means.

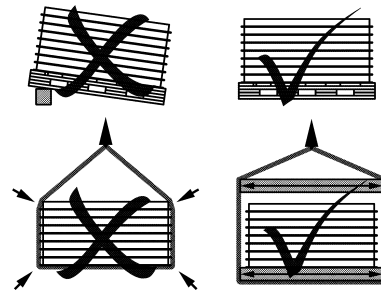

Store and handle the materials with care.

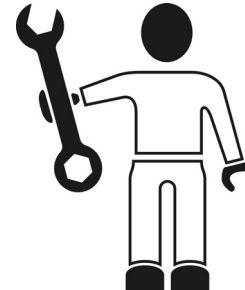

Assemble by qualified staff only.



Do not expose the materials to the natural agents.